

Flansch

Für Saug- und Druckanschluss
an Zahnrädern

Abmessungen

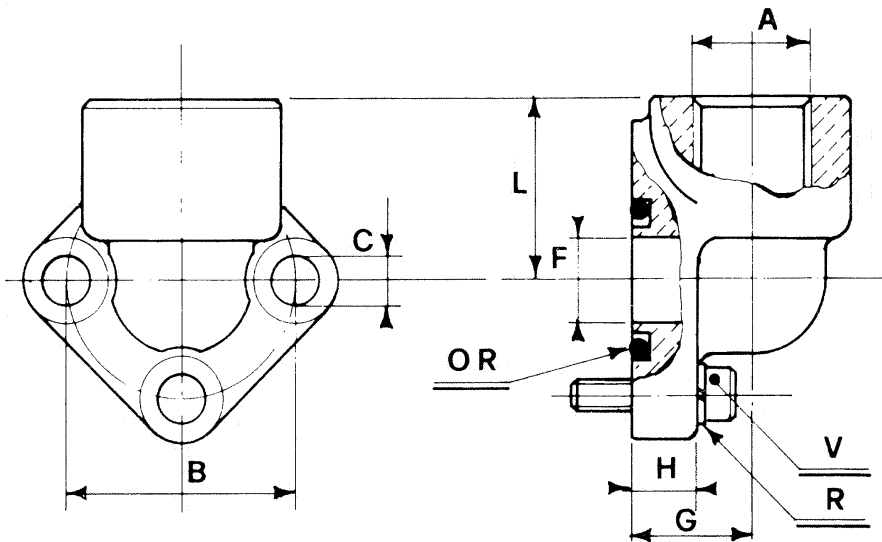

Ident.-Nr.	Pumpen- größe	Abmessungen								Anzahl Bef.-Schraub.	Schrauben- größe	Innendurchm. Federring
		A	B	C	F	G	H	L				
KN2895	1	3/8"	30	6,5	12	17	9,5	27	3	M6x20	6,4	
KN2896	1	1/2"	30	6,5	12	17	9,5	27	3	M6x20	6,4	
KN2897	2	1/2"	40	8,5	20	22	12	36	3	M8x25	8,4	
KN2898	2	3/4"	40	8,5	20	22	12	36	3	M8x25	8,4	
KN2899	3	3/4"	51	11	24	26	13	48	3	M10x30	10,5	
KN2443	3	1"	51	11	24	26	13	48	3	M10x30	10,5	
KN2900	3	3/4"	56	11	24	26	13	48	3	M10x30	10,5	
KN2444	3	1"	56	11	24	26	13	48	3	M10x30	10,5	

Max. Betriebsdruck 315 bar

Werkstoff Stahl

Bestellangaben **Flansch**

KN2895

KN2896

:

